

2-SAT

2-SAT

Input: A formula ϕ consisting of

- A set of n boolean variables x_1, \dots, x_n
- A conjunction of m clauses C_1, \dots, C_m , i.e., disjunctions of 2 literals $C_j = (c_j^{(1)} \vee c_j^{(2)})$, where a literal is either a variable or its negation.

A truth assignment is a function $\tau : \{x_1, \dots, x_n\} \rightarrow \{\top, \perp\}$

- A clause $C_j = (c_j^{(1)} \vee c_j^{(2)})$ is *satisfied* by τ according to the rules of boolean algebra.
- ϕ is satisfied iff all m clauses C_1, \dots, C_m are satisfied.

Question: Is there a truth assignment that satisfies ϕ ?

Example

Formula

$$\phi = (x_1 \vee \overline{x_2}) \wedge (x_2 \vee x_4) \wedge (\overline{x_1} \vee \overline{x_3}) \wedge (x_3 \vee \overline{x_2}) \wedge (\overline{x_1} \vee \overline{x_4})$$

Example

Formula

$$\phi = (x_1 \vee \overline{x_2}) \wedge (x_2 \vee x_4) \wedge (\overline{x_1} \vee \overline{x_3}) \wedge (x_3 \vee \overline{x_2}) \wedge (\overline{x_1} \vee \overline{x_4})$$

Satisfying assignment:

$$x_1 = \perp \quad x_2 = \perp \quad x_3 = \top \quad x_4 = \top$$

Example

Formula

$$\phi = (x_1 \vee \overline{x_2}) \wedge (x_2 \vee x_4) \wedge (\overline{x_1} \vee \overline{x_3}) \wedge (x_3 \vee \overline{x_2}) \wedge (\overline{x_1} \vee \overline{x_4})$$

Satisfying assignment:

$$x_1 = \perp \quad x_2 = \perp \quad x_3 = \top \quad x_4 = \top$$

Trivial solution $O^*(2^n)$

An Observation

- A clause of the form $(\neg x_i \vee x_j)$ corresponds to $x_i \implies x_j$
- If $x_i = \top$ then, in any satisfying assignment, $x_j = \top$
- We say that x_j is **implied**.
- The same holds for any clause $C_j = (c_j^{(1)} \vee c_j^{(2)})$
- If $c_j^{(1)} = \perp$, then $c_j^{(2)} = \top$
- We say that the variable x_k corresponding to $c_j^{(2)}$ **implied**.
- If $c_j^{(2)} = x_k$, then $x_k = \top$. If $c_j^{(2)} = \overline{x_k}$, then $x_k = \perp$.

Example

$$\phi = (x_1 \vee \overline{x_2}) \wedge (x_2 \vee x_4) \wedge (\overline{x_1} \vee \overline{x_3}) \wedge (x_3 \vee \overline{x_2}) \wedge (\overline{x_1} \vee \overline{x_4})$$

Example

$$\phi = (x_1 \vee \overline{x_2}) \wedge (x_2 \vee x_4) \wedge (\overline{x_1} \vee \overline{x_3}) \wedge (x_3 \vee \overline{x_2}) \wedge (\overline{x_1} \vee \overline{x_4})$$

Assume that $x_1 = \top$

Example

$$\phi = (x_1 \vee \overline{x_2}) \wedge (x_2 \vee x_4) \wedge (\overline{x_1} \vee \overline{x_3}) \wedge (x_3 \vee \overline{x_2}) \wedge (\overline{x_1} \vee \overline{x_4})$$

Assume that $x_1 = \top$

x_3 and x_4 are implied. $x_3 = \perp$ and $x_4 = \perp$

Example

$$\phi = (x_1 \vee \overline{x_2}) \wedge (\underline{x_2} \vee x_4) \wedge (\overline{x_1} \vee \underline{\overline{x_3}}) \wedge (x_3 \vee \overline{x_2}) \wedge (\overline{x_1} \vee \underline{\overline{x_4}})$$

Assume that $x_1 = \top$

x_3 and x_4 are implied. $x_3 = \perp$ and $x_4 = \perp$

$x_2 = \top$ is implied

Example

$$\phi = (x_1 \vee \overline{x_2}) \wedge (\underline{x_2} \vee x_4) \wedge (\overline{x_1} \vee \underline{\overline{x_3}}) \wedge (\underline{x_3} \vee \overline{x_2}) \wedge (\overline{x_1} \vee \underline{\overline{x_4}})$$

Assume that $x_1 = \top$

x_3 and x_4 are implied. $x_3 = \perp$ and $x_4 = \perp$

$x_2 = \top$ is implied

$x_2 = \perp$ is implied, a contradiction!

Example

$$\phi = (x_1 \vee \overline{x_2}) \wedge (x_2 \vee x_4) \wedge (\overline{x_1} \vee \overline{x_3}) \wedge (x_3 \vee \overline{x_2}) \wedge (\overline{x_1} \vee \overline{x_4})$$

Assume that $x_1 = \perp$

Example

$$\phi = (x_1 \vee \underline{\overline{x_2}}) \wedge (x_2 \vee x_4) \wedge (\overline{x_1} \vee \overline{x_3}) \wedge (x_3 \vee \overline{x_2}) \wedge (\overline{x_1} \vee \overline{x_4})$$

Assume that $x_1 = \perp$

$x_2 = \perp$ is implied.

Example

$$\phi = (x_1 \vee \underline{\overline{x_2}}) \wedge (x_2 \vee \underline{x_4}) \wedge (\overline{x_1} \vee \overline{x_3}) \wedge (x_3 \vee \overline{x_2}) \wedge (\overline{x_1} \vee \overline{x_4})$$

Assume that $x_1 = \perp$

$x_2 = \perp$ is implied.

$x_4 = \top$ is implied.

Example

$$\phi = (x_1 \vee \overline{x_2}) \wedge (x_2 \vee \overline{x_4}) \wedge (\overline{x_1} \vee \overline{x_3}) \wedge (x_3 \vee \overline{x_2}) \wedge (\overline{x_1} \vee \overline{x_4})$$

Assume that $x_1 = \perp$

$x_2 = \perp$ is implied.

$x_4 = \top$ is implied.

We found a satisfying assignment. (x_3 can be set to either \top or \perp)

The Implication Graph

Given ϕ we construct a directed graph $G_\phi = (V, E)$ where:

- The vertices of G are all possible literals of ϕ , i.e., for each variable x_i we add both x_i and $\overline{x_i}$ to V .
- For each clause $(l_i \vee l_j)$:
 - Add $(\overline{l_i}, l_j)$ to E
 - Add $(\overline{l_j}, l_i)$ to E
- Intuitively $(u, v) \in E$ means that if $u = \top$, then we must set $v = \top$.

Example

$$\phi = (x_1 \vee \overline{x_2}) \wedge (x_2 \vee x_4) \wedge (\overline{x_1} \vee \overline{x_3}) \wedge (x_3 \vee x_4) \wedge (\overline{x_1} \vee \overline{x_4})$$

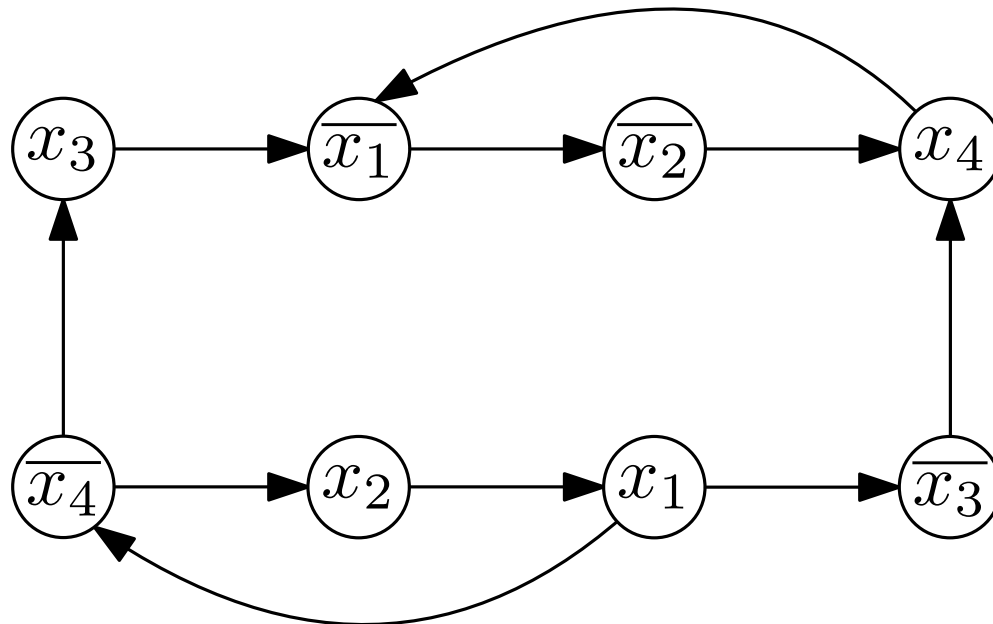

A useful property

Claim: G_ϕ is skew-symmetric: If there is a path P from l_i to l_j in G_ϕ , then there is also a path from $\overline{l_j}$ to $\overline{l_i}$.

- Pick any edge (l_k, l_{k+1}) of P .

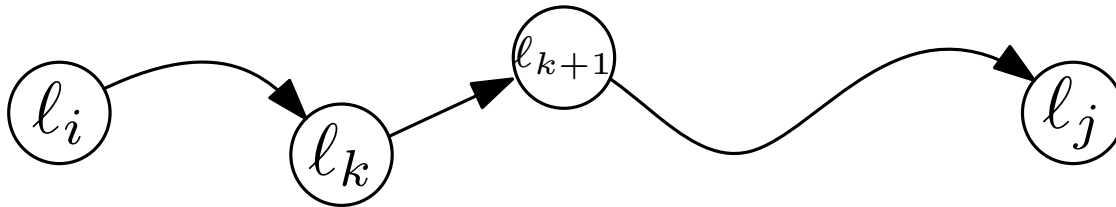

- The edge (l_k, l_{k+1}) must have been created from the clause $(\overline{l_k} \vee l_{k+1})$.
- The clause $(\overline{l_k} \vee l_{k+1})$ also creates the edge $(\overline{l_{k+1}}, \overline{l_k})$.

Strongly Connected Components

Definition: A strongly connected component of a graph $G = (V, E)$ is a maximal set $C \subseteq V$ such that $\forall x, y \in C$, there is a path from x to y in G .

Strongly Connected Components

Definition: A strongly connected component of a graph $G = (V, E)$ is a maximal set $C \subseteq V$ such that $\forall x, y \in C$, there is a path from x to y in G .

$$\phi = (x_1 \vee \overline{x_2}) \wedge (x_2 \vee x_4) \wedge (\overline{x_1} \vee \overline{x_3}) \wedge (x_3 \vee x_4) \wedge (\overline{x_1} \vee \overline{x_4})$$

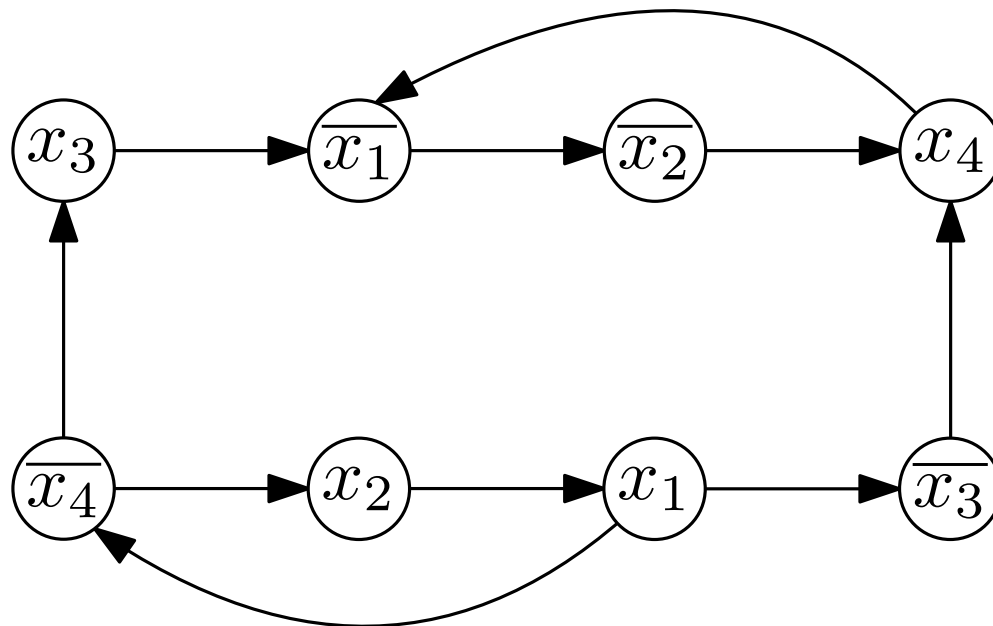

Strongly Connected Components

Definition: A strongly connected component of a graph $G = (V, E)$ is a maximal set $C \subseteq V$ such that $\forall x, y \in C$, there is a path from x to y in G .

$$\phi = (x_1 \vee \overline{x_2}) \wedge (x_2 \vee x_4) \wedge (\overline{x_1} \vee \overline{x_3}) \wedge (x_3 \vee x_4) \wedge (\overline{x_1} \vee \overline{x_4})$$

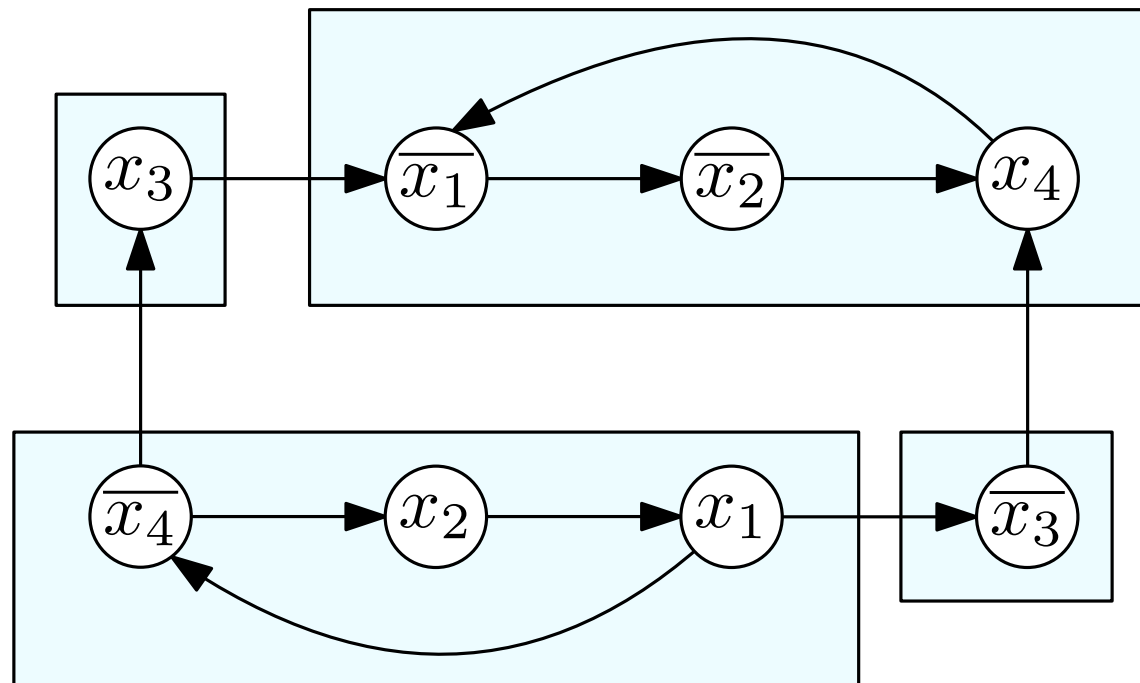

Contracted Graph

Construct a new graph $G'_\phi = (V', E')$ from $G_\phi = (V, E)$:

- Each vertex in V' is a SCC of G .
- There is an edge between a pair of distinct connected components $(C, C') \in E$ iff $\exists x \in C, y \in C'$ such that $(x, y) \in E$.

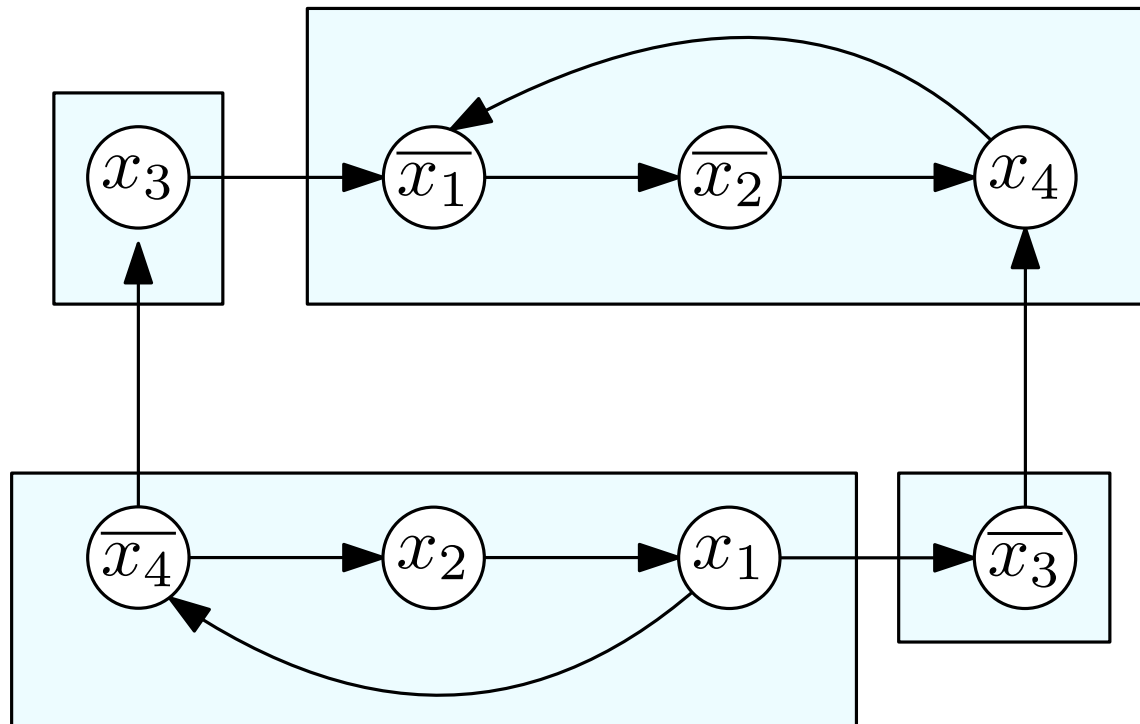

Contracted Graph

Construct a new graph $G'_\phi = (V', E')$ from $G_\phi = (V, E)$:

- Each vertex in V' is a SCC of G .
- There is an edge between a pair of distinct connected components $(C, C') \in E$ iff $\exists x \in C, y \in C'$ such that $(x, y) \in E$.

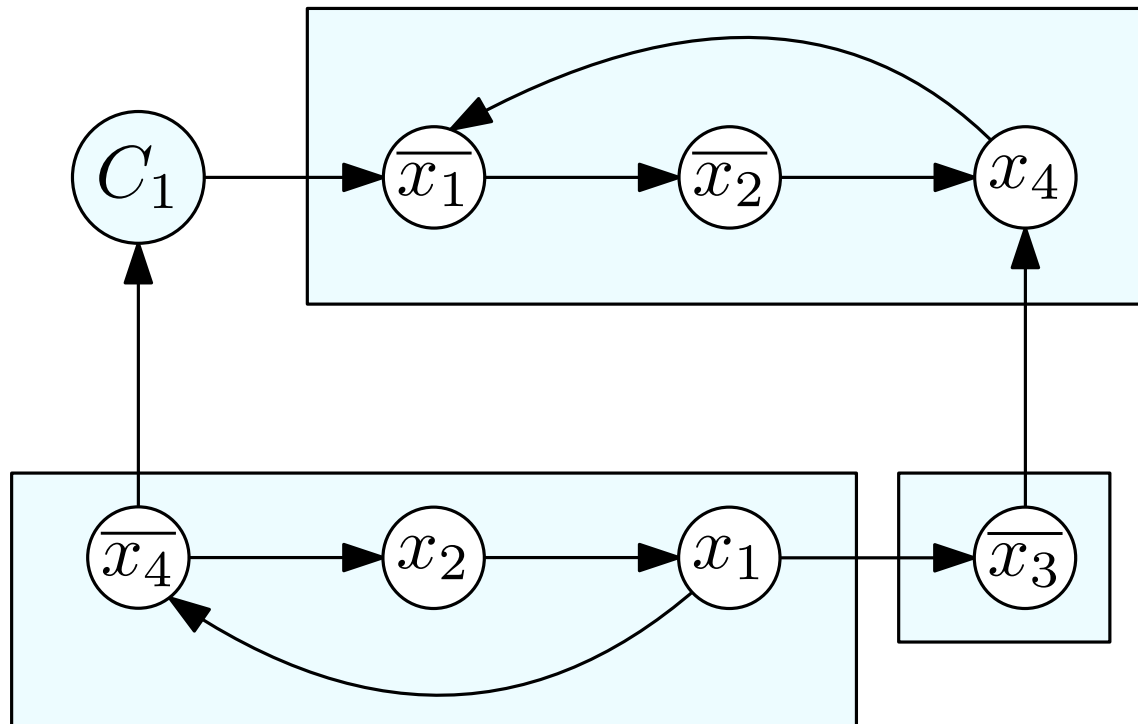

Contracted Graph

Construct a new graph $G'_\phi = (V', E')$ from $G_\phi = (V, E)$:

- Each vertex in V' is a SCC of G .
- There is an edge between a pair of distinct connected components $(C, C') \in E$ iff $\exists x \in C, y \in C'$ such that $(x, y) \in E$.

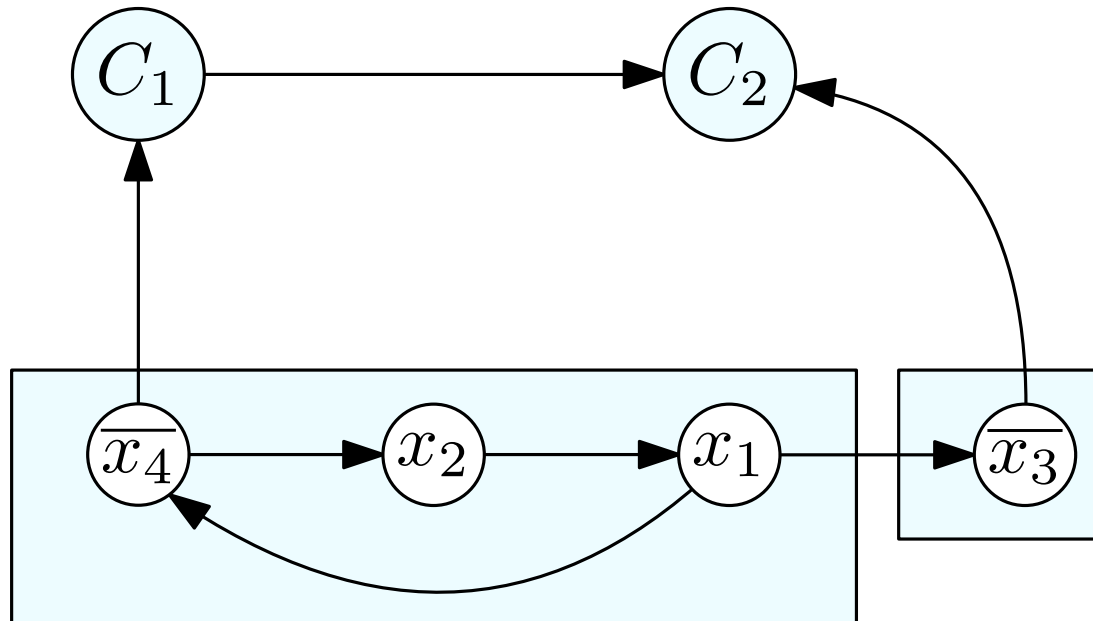

Contracted Graph

Construct a new graph $G'_\phi = (V', E')$ from $G_\phi = (V, E)$:

- Each vertex in V' is a SCC of G .
- There is an edge between a pair of distinct connected components $(C, C') \in E$ iff $\exists x \in C, y \in C'$ such that $(x, y) \in E$.

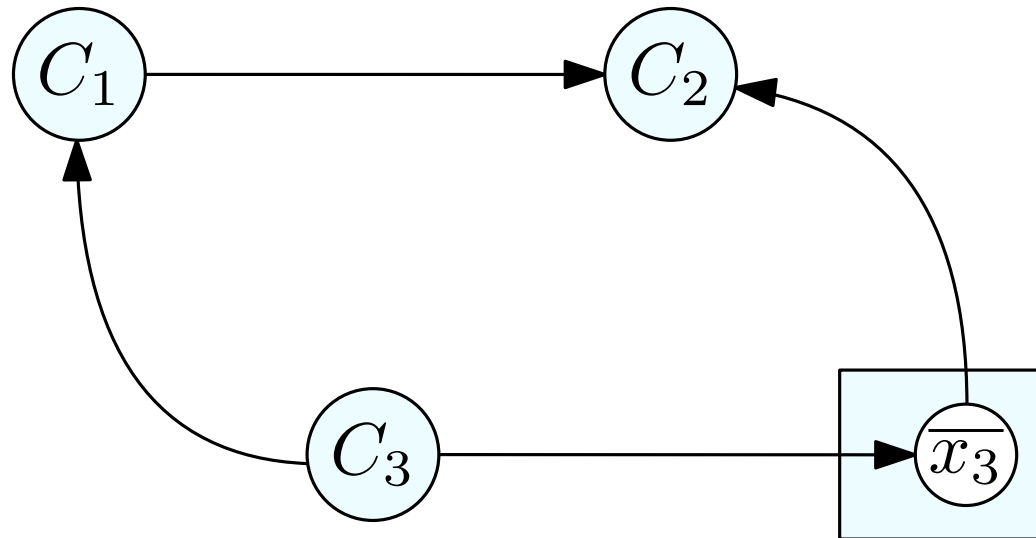

Contracted Graph

Construct a new graph $G'_\phi = (V', E')$ from $G_\phi = (V, E)$:

- Each vertex in V' is a SCC of G .
- There is an edge between a pair of distinct connected components $(C, C') \in E$ iff $\exists x \in C, y \in C'$ such that $(x, y) \in E$.

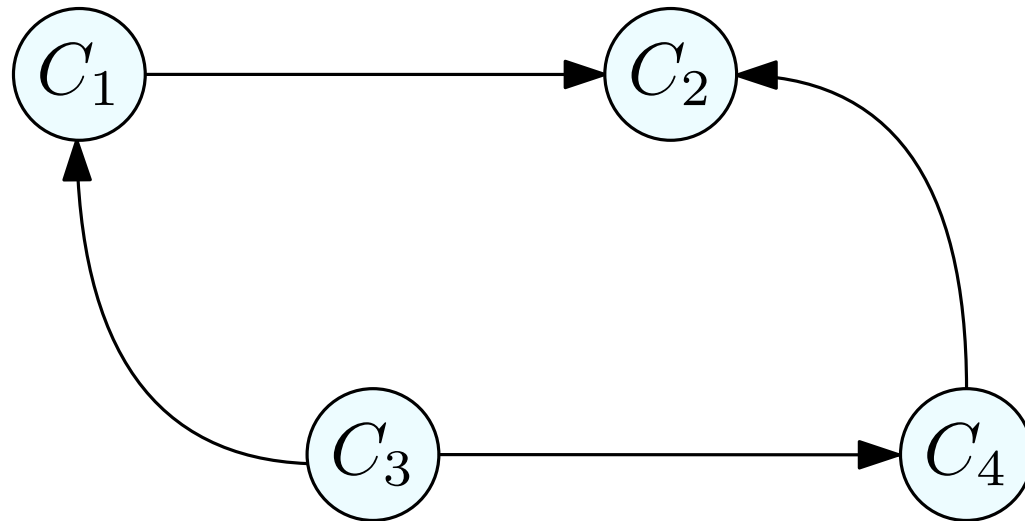

Topological Order

Observation: Contracting the SCCs of a directed graph yields a directed acyclic graph.

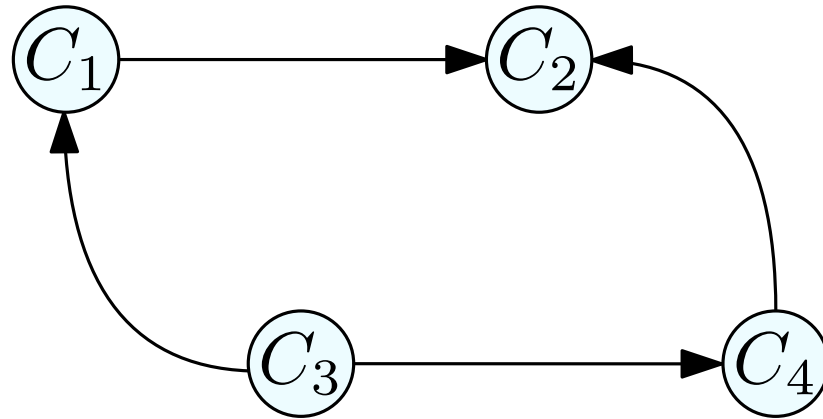

Topological Order

Observation: Contracting the SCCs of a directed graph yields a directed acyclic graph.

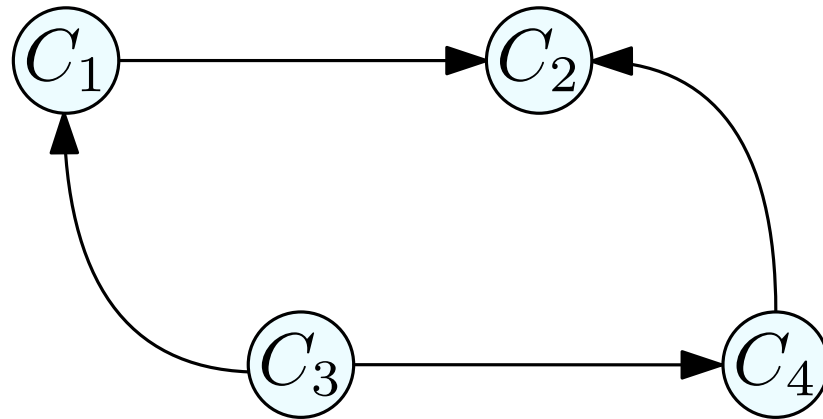

Definition: A topological order of a directed acyclic graph is a linear order v_1, v_2, \dots of the vertices such that, for any edge (v_i, v_j) , we have $i < j$.

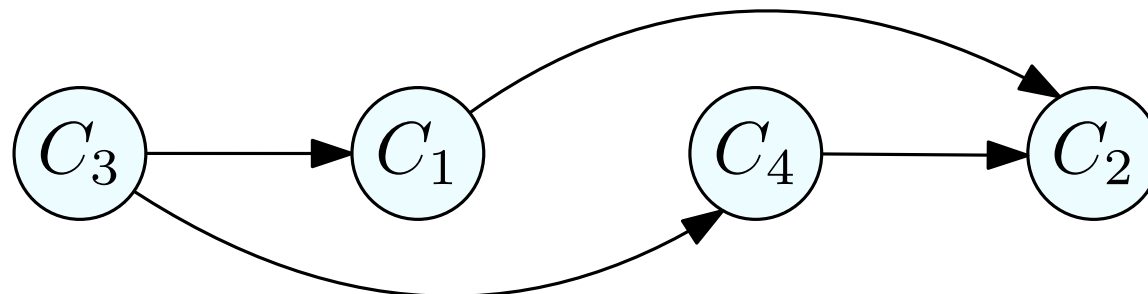

Relation between SSCs and 2-SAT

Claim 1: If, for some x_i , both x_i and $\overline{x_i}$ belong to the same SCC C , then ϕ is not satisfiable.

Relation between SSCs and 2-SAT

Claim 1: If, for some x_i , both x_i and $\overline{x_i}$ belong to the same SCC C , then ϕ is not satisfiable.

- Since x_i and $\overline{x_i}$ are in the same SCC, there is a path P in G from x_i to $\overline{x_i}$ and a path P' from $\overline{x_i}$ to x_i .

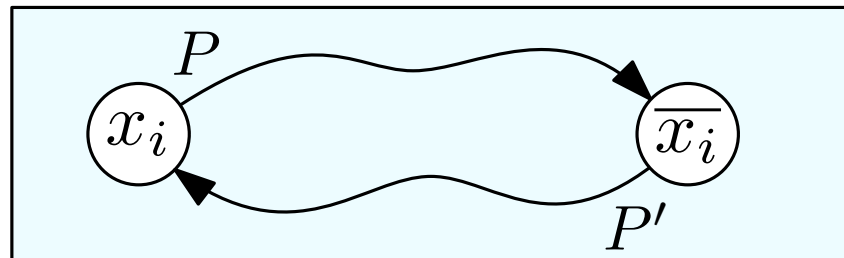

Relation between SSCs and 2-SAT

Claim 1: If, for some x_i , both x_i and $\overline{x_i}$ belong to the same SCC C , then ϕ is not satisfiable.

- Since x_i and $\overline{x_i}$ are in the same SCC, there is a path P in G from x_i to $\overline{x_i}$ and a path P' from $\overline{x_i}$ to x_i .

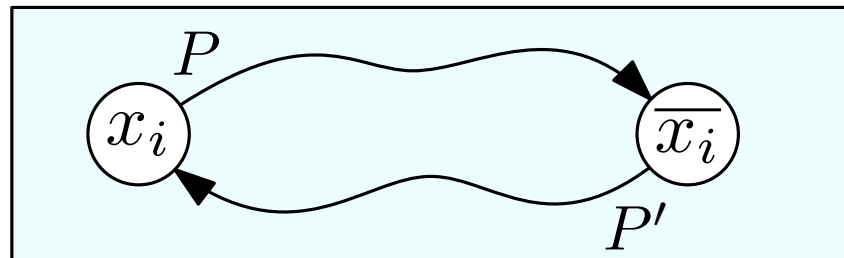

- In any satisfying assignment, we cannot have $x_i = \top$, since it would imply (through P) that $\overline{x_i} = \top$, i.e., $x_i = \perp$. ζ

Relation between SSCs and 2-SAT

Claim 1: If, for some x_i , both x_i and $\overline{x_i}$ belong to the same SCC C , then ϕ is not satisfiable.

- Since x_i and $\overline{x_i}$ are in the same SCC, there is a path P in G from x_i to $\overline{x_i}$ and a path P' from $\overline{x_i}$ to x_i .

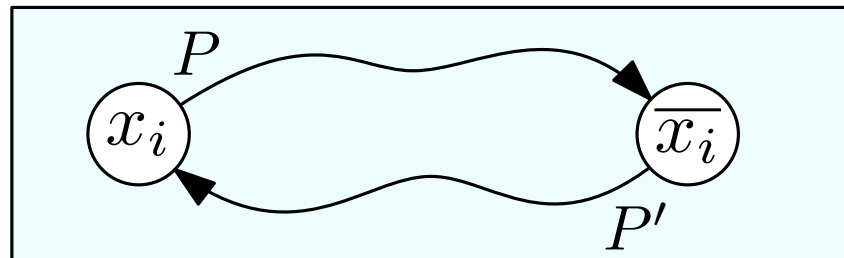

- In any satisfying assignment, we cannot have $x_i = \top$, since it would imply (through P) that $\overline{x_i} = \top$, i.e., $x_i = \perp$. ζ
- A symmetric argument shows that we cannot have $x_i = \perp$ since it would imply $x_i = \top$ through P' . ζ

Relation between SSCs and 2-SAT

Assumption: for all x_i , x_i and $\overline{x_i}$ belong to different SCCs.

An algorithm:

- \forall SCC $C = C_1, C_2, \dots$ of G in reverse topological order.
 - Assign all unassigned literals of C to \top and their complement to \perp .

Relation between SSCs and 2-SAT

Assumption: for all x_i , x_i and $\overline{x_i}$ belong to different SCCs.

An algorithm:

- \forall SCC $C = C_1, C_2, \dots$ of G in reverse topological order.
 - Assign all unassigned literals of C to \top and their complement to \perp .

Claim 2: When l_i is set to \top , all literals l_j reachable from l_i in G are set to \top .

Proof: By induction on the index k of the SCC C_k containing l_i .

Relation between SSCs and 2-SAT

Suppose that there is a neighbor l_j of l_i such that $l_j = \perp$.

By skew-symmetry G contains the edge $(\overline{l_j}, \overline{l_i})$

$\overline{l_j}$ is set to \top and must belong to a SCC C_h for some $h \leq k$.

If $h = k$:

Relation between SSCs and 2-SAT

Suppose that there is a neighbor l_j of l_i such that $l_j = \perp$.

By skew-symmetry G contains the edge $(\overline{l_j}, \overline{l_i})$

$\overline{l_j}$ is set to \top and must belong to a SCC C_h for some $h \leq k$.

If $h = k$:

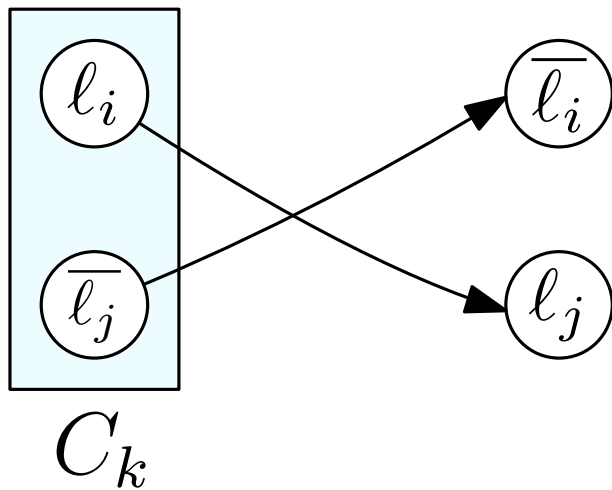

Relation between SSCs and 2-SAT

Suppose that there is a neighbor l_j of l_i such that $l_j = \perp$.

By skew-symmetry G contains the edge $(\overline{l_j}, \overline{l_i})$

$\overline{l_j}$ is set to \top and must belong to a SCC C_h for some $h \leq k$.

If $h = k$:

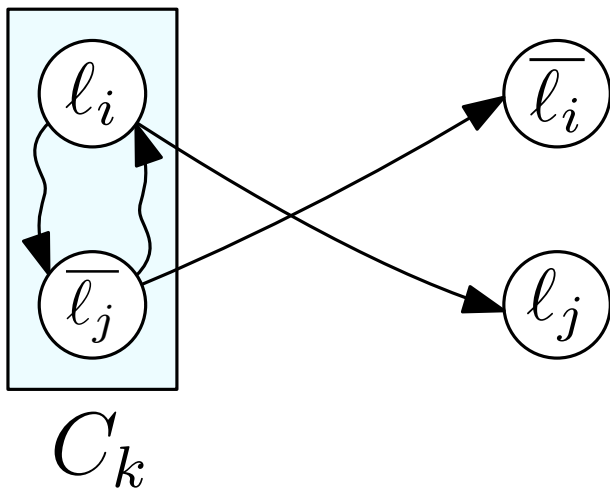

Relation between SSCs and 2-SAT

Suppose that there is a neighbor l_j of l_i such that $l_j = \perp$.

By skew-symmetry G contains the edge $(\overline{l_j}, \overline{l_i})$

$\overline{l_j}$ is set to \top and must belong to a SCC C_h for some $h \leq k$.

If $h = k$:

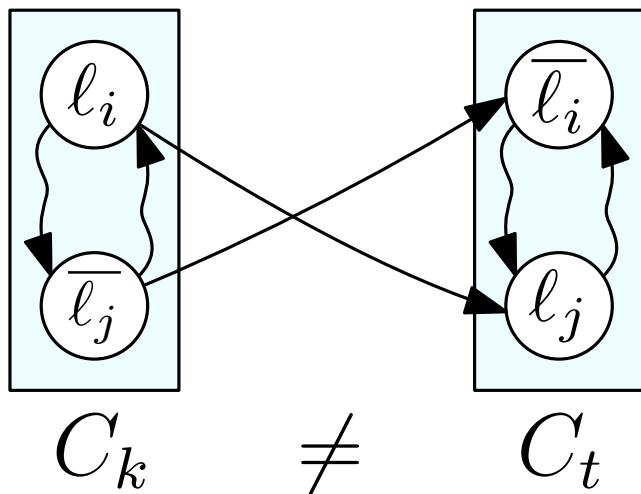

- $C_k \neq C_t$ (otherwise $l_i, \overline{l_i} \in C_k$)

Relation between SSCs and 2-SAT

Suppose that there is a neighbor l_j of l_i such that $l_j = \perp$.

By skew-symmetry G contains the edge $(\overline{l_j}, \overline{l_i})$

$\overline{l_j}$ is set to \top and must belong to a SCC C_h for some $h \leq k$.

If $h = k$:

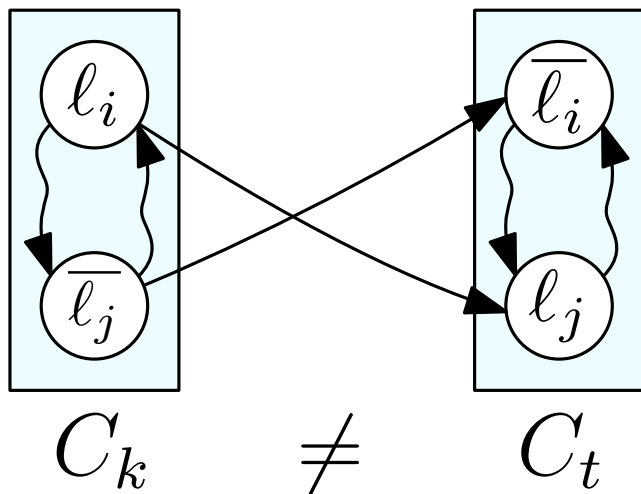

- $C_k \neq C_t$ (otherwise $l_i, \overline{l_i} \in C_k$)
- $(C_k, C_t) \in E' \implies t < k$

Relation between SSCs and 2-SAT

Suppose that there is a neighbor l_j of l_i such that $l_j = \perp$.

By skew-symmetry G contains the edge (\bar{l}_j, \bar{l}_i)

\bar{l}_j is set to \top and must belong to a SCC C_h for some $h \leq k$.

If $h = k$:

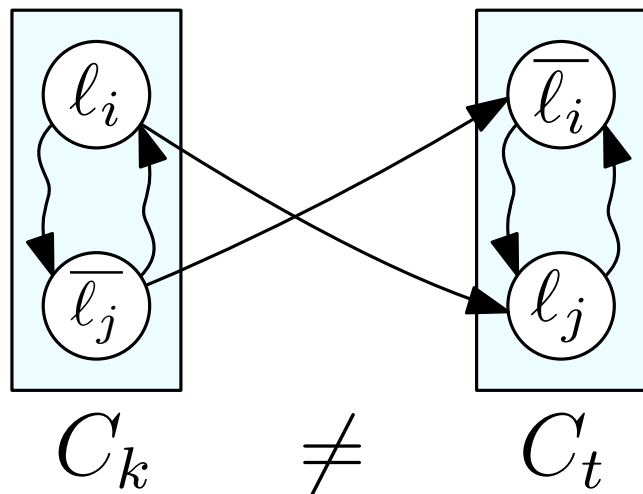

- $C_k \neq C_t$ (otherwise $l_i, \bar{l}_i \in C_k$)
- $(C_k, C_t) \in E' \implies t < k$
- After C_t was considered $\bar{l}_i = \top \implies l_i = \perp$.



Relation between SSCs and 2-SAT

Suppose that there is a neighbor l_j of l_i such that $l_j = \perp$.

By skew-symmetry G contains the edge (\bar{l}_j, \bar{l}_i)

\bar{l}_j is set to \top and must belong to a SCC C_h for some $h \leq k$.

If $h = k$:

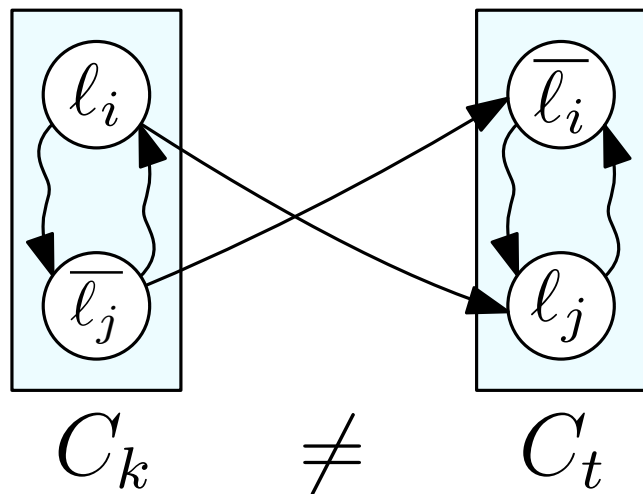

- $C_k \neq C_t$ (otherwise $l_i, \bar{l}_i \in C_k$)
- $(C_k, C_t) \in E' \implies t < k$
- After C_t was considered $\bar{l}_i = \top \implies l_i = \perp$. ⚡

If $h < k$:

By inductive hypothesis, all neighbors of \bar{l}_j are set to \top , i.e.,

$\bar{l}_i = \top \implies l_i = \perp$. ⚡

Relation between SSCs and 2-SAT

Claim 1: If, for some x_i , both x_i and $\overline{x_i}$ belong to the same SCC C , then ϕ is not satisfiable.

Assumption: $\forall x_i$, x_i and $\overline{x_i}$ belong to different SCCs.

Claim 2: When l_i is set to \top , all literals l_j reachable from l_i in G are set to \top .

Relation between SSCs and 2-SAT

Claim 1: If, for some x_i , both x_i and $\overline{x_i}$ belong to the same SCC C , then ϕ is not satisfiable.

Assumption: $\forall x_i$, x_i and $\overline{x_i}$ belong to different SCCs.

Claim 2: When l_i is set to \top , all literals l_j reachable from l_i in G are set to \top .

Corollary: ϕ is satisfiable iff $\forall x_i$, x_i and $\overline{x_i}$ belong to different SCCs. The algorithm computes a satisfying assignment.

- Consider a generic clause $(l_i \vee l_j)$
- If l_i is set to \top , the clause is satisfied.
- If l_i is set to \perp : $\overline{l_i} = \top$ and G contains the edge $(\overline{l_i}, l_j)$. The claim implies that $l_j = \top$.

Time Complexity

Satisfiability

(Assuming $m = \Omega(n)$)

- Construct the implication graph G_ϕ $O(m)$
- Compute the SSCs of G_ϕ $O(m)$
- If a SCC of G contains both x_i and $\overline{x_i}$, for some x_i : $O(n)$
 - Return “ ϕ is not satisfiable”
- Return “ ϕ is satisfiable”

Time Complexity

Satisfying assignment

(Assuming $m = \Omega(n)$)

- Construct the implication graph G_ϕ $O(m)$
- Compute the SSCs of G_ϕ $O(m)$
- If a SCC of G contains both x_i and $\overline{x_i}$, for some x_i : $O(n)$
 - Return “ ϕ is not satisfiable”
- $G'_\phi \leftarrow$ Contract the SSCs of G_ϕ $O(m)$
- Topologically sort G' $O(m)$
- \forall SCC C of G in reverse topological order.
 - Assign all unassigned literals of C to \top and their complement to \perp .

} $O(n)$

Time Complexity

Satisfying assignment

(Assuming $m = \Omega(n)$)

- Construct the implication graph G_ϕ $O(m)$
- Compute the SSCs of G_ϕ **How?** $O(m)$
- If a SCC of G contains both x_i and $\overline{x_i}$, for some x_i : $O(n)$
 - Return “ ϕ is not satisfiable”
- $G'_\phi \leftarrow$ Contract the SSCs of G_ϕ $O(m)$
- Topologically sort G' $O(m)$
- \forall SCC C of G in reverse topological order.
 - Assign all unassigned literals of C to \top and their complement to \perp .

} $O(n)$